

1 Part list: IG.NR. 235907

(x4) A	(x4) B	(x2) C	(x2) D 25cm. Tape	(x4) E	(x4) F
(x4) G	(x1) H	(x2) I	(x2) J	(x1) K	(x1) L
(x1) M	(x2) N	(x4) O	(x3) P		

Tool list:

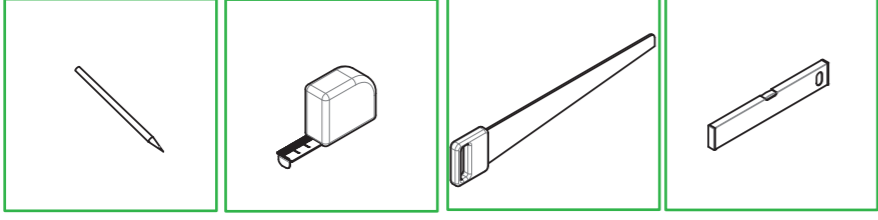

TRAPVERBINDING WIT

2 Where to use:

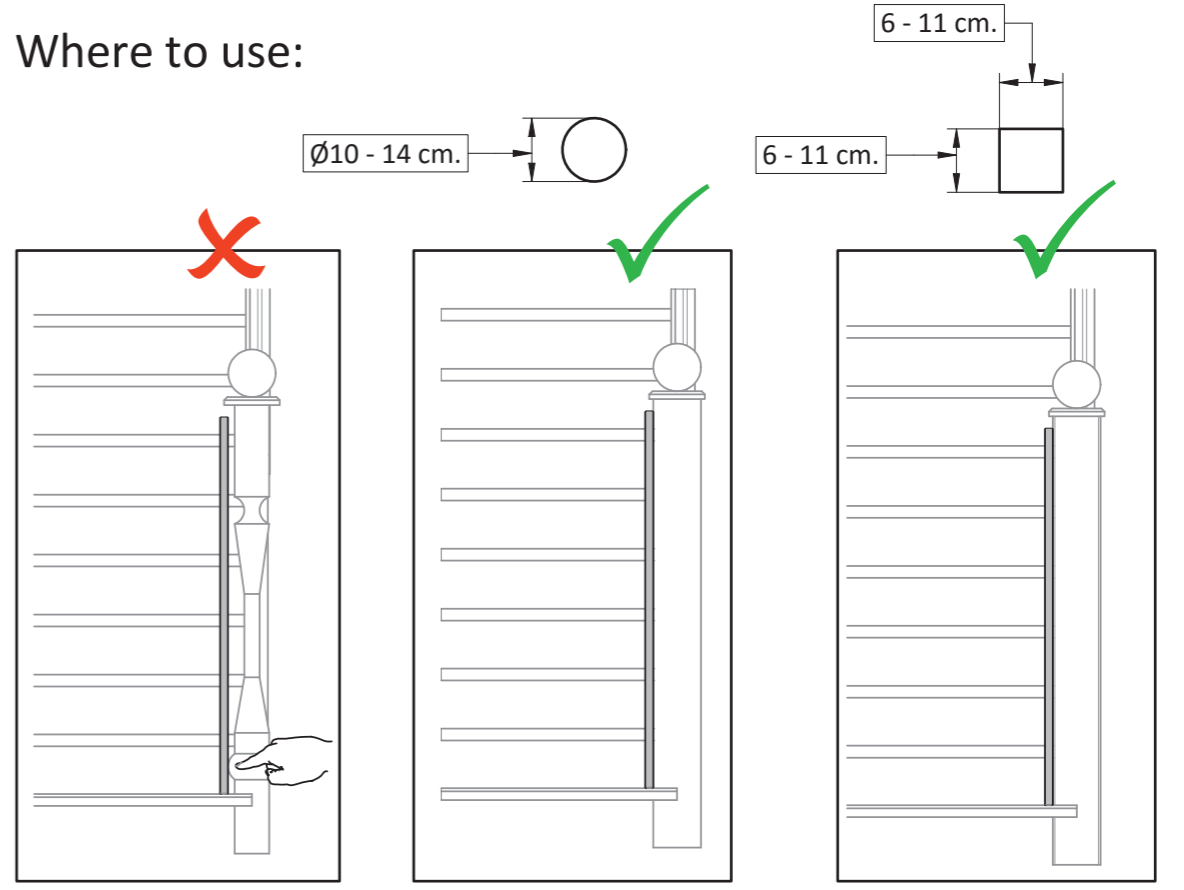

Ø10 - 14 cm. 6 - 11 cm. 6 - 11 cm.

3

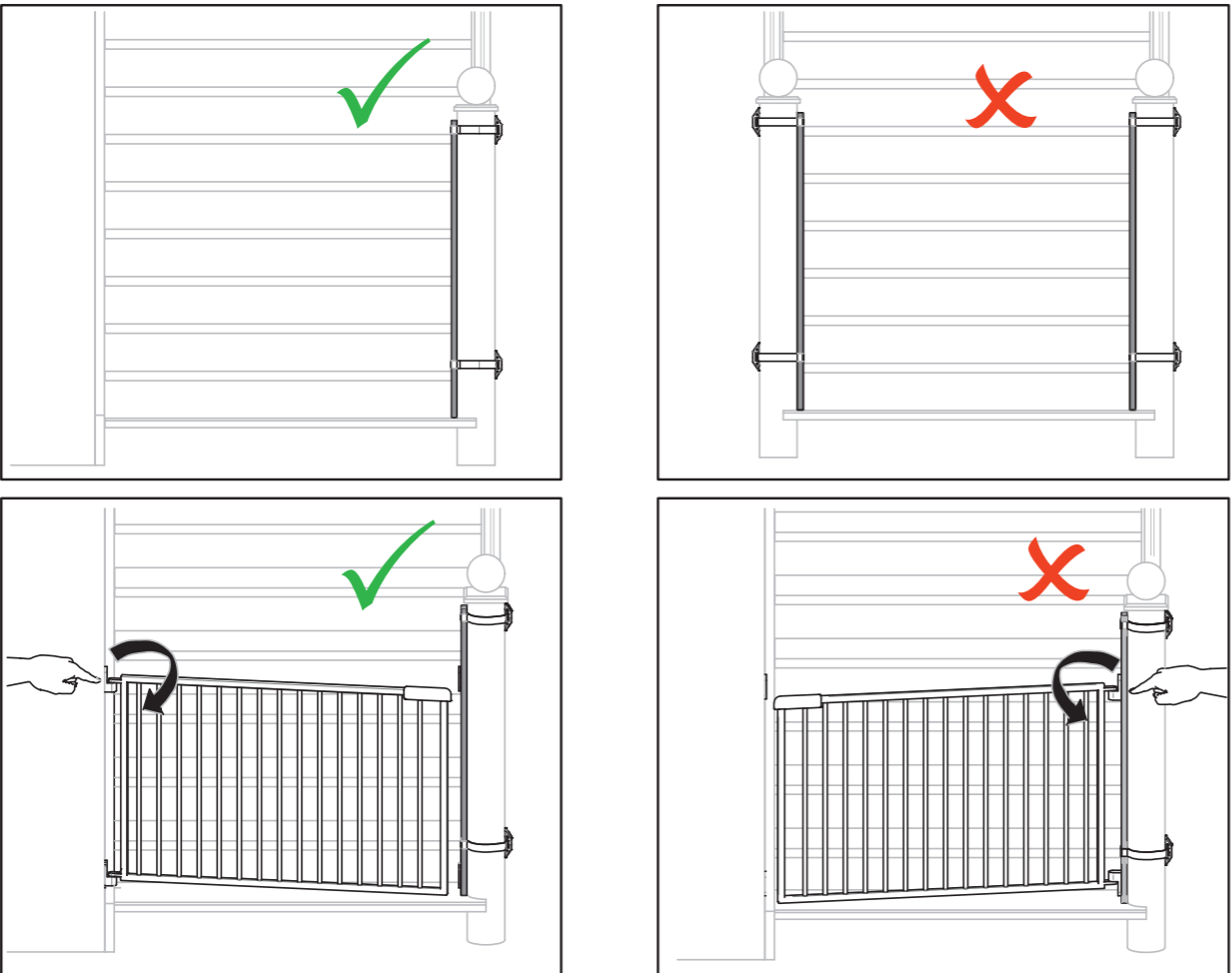

4 How to mount:

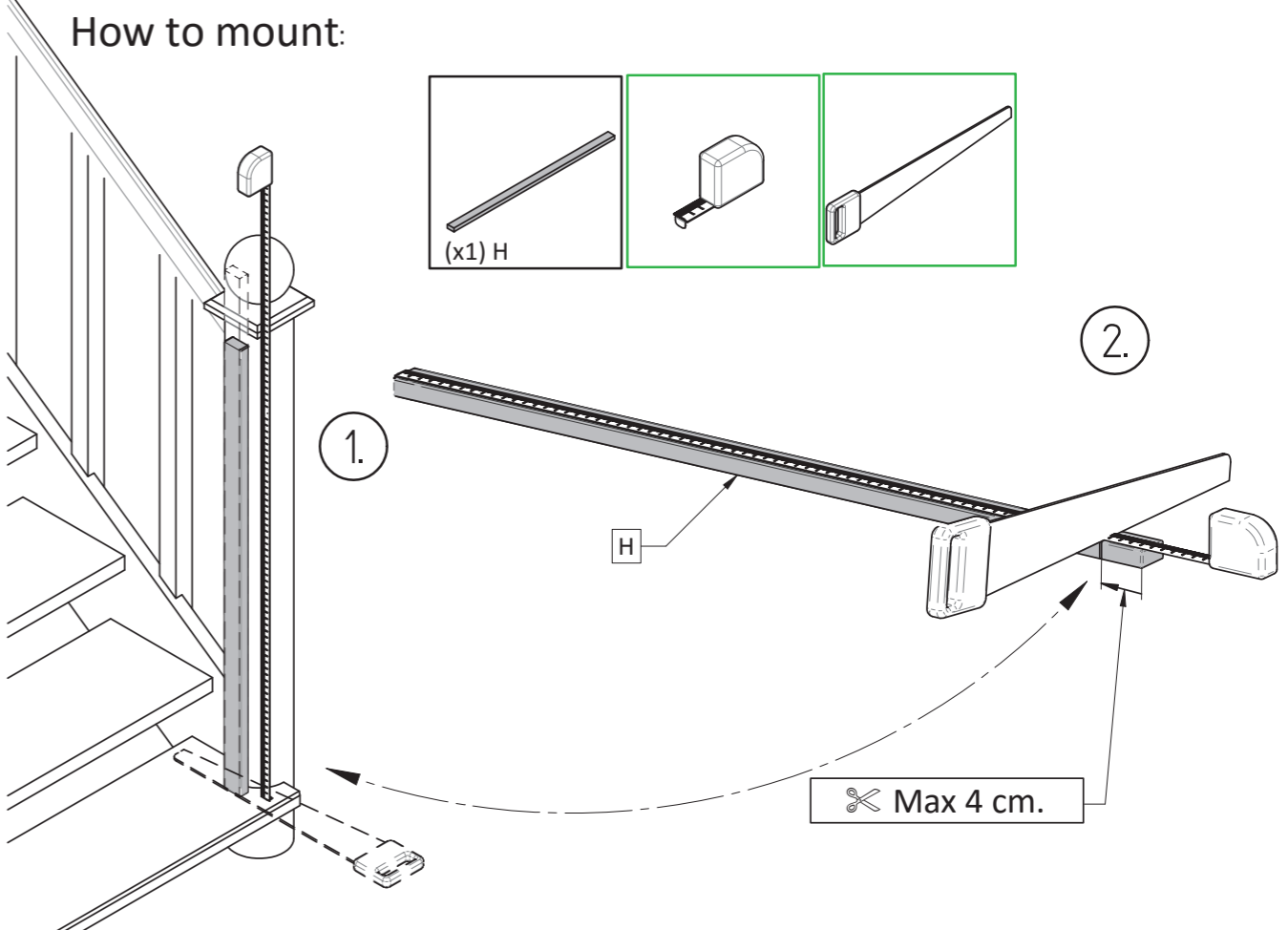

(x1) H. Max 4 cm.

5

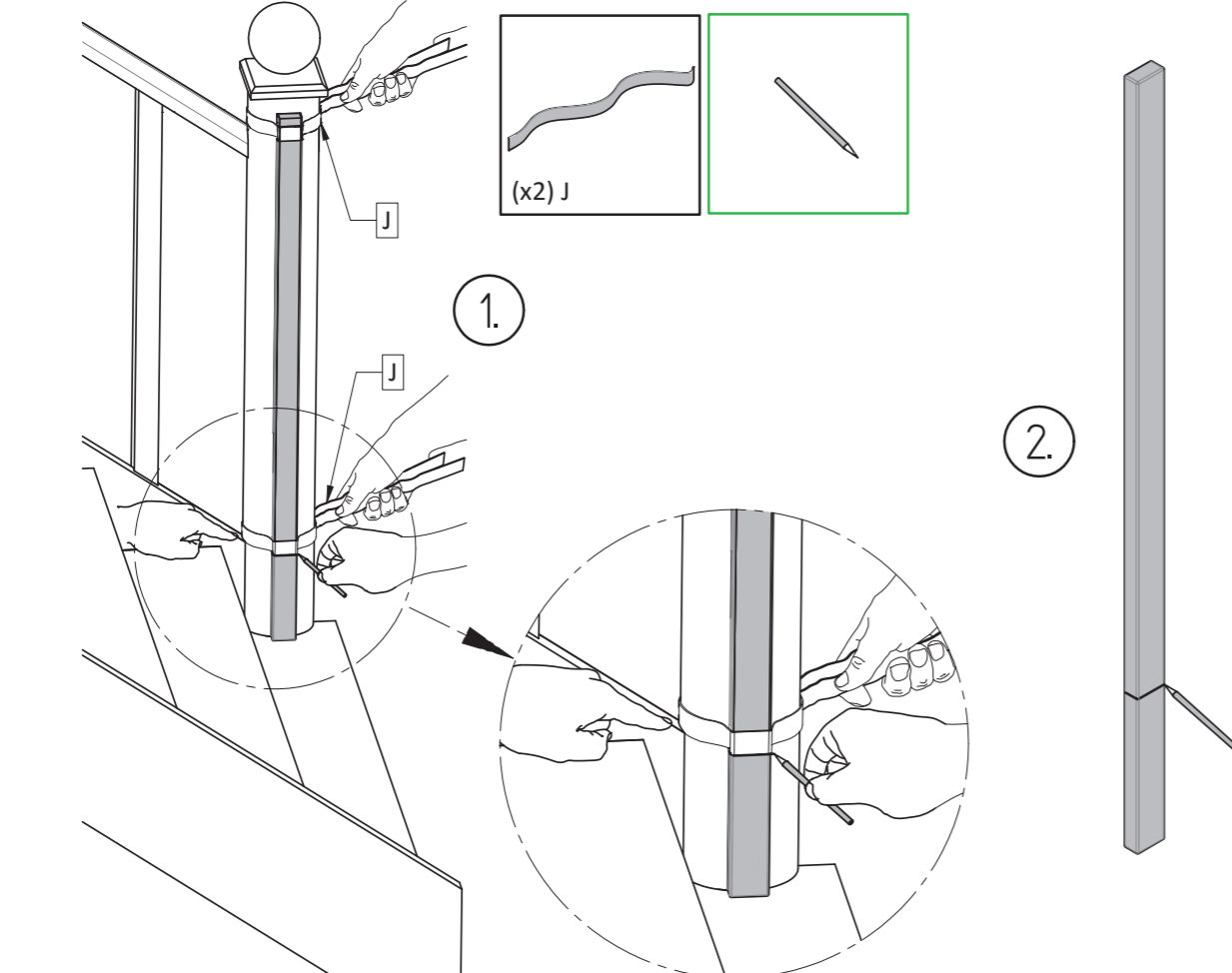

(x2) J. Top. Max 3 cm.

6

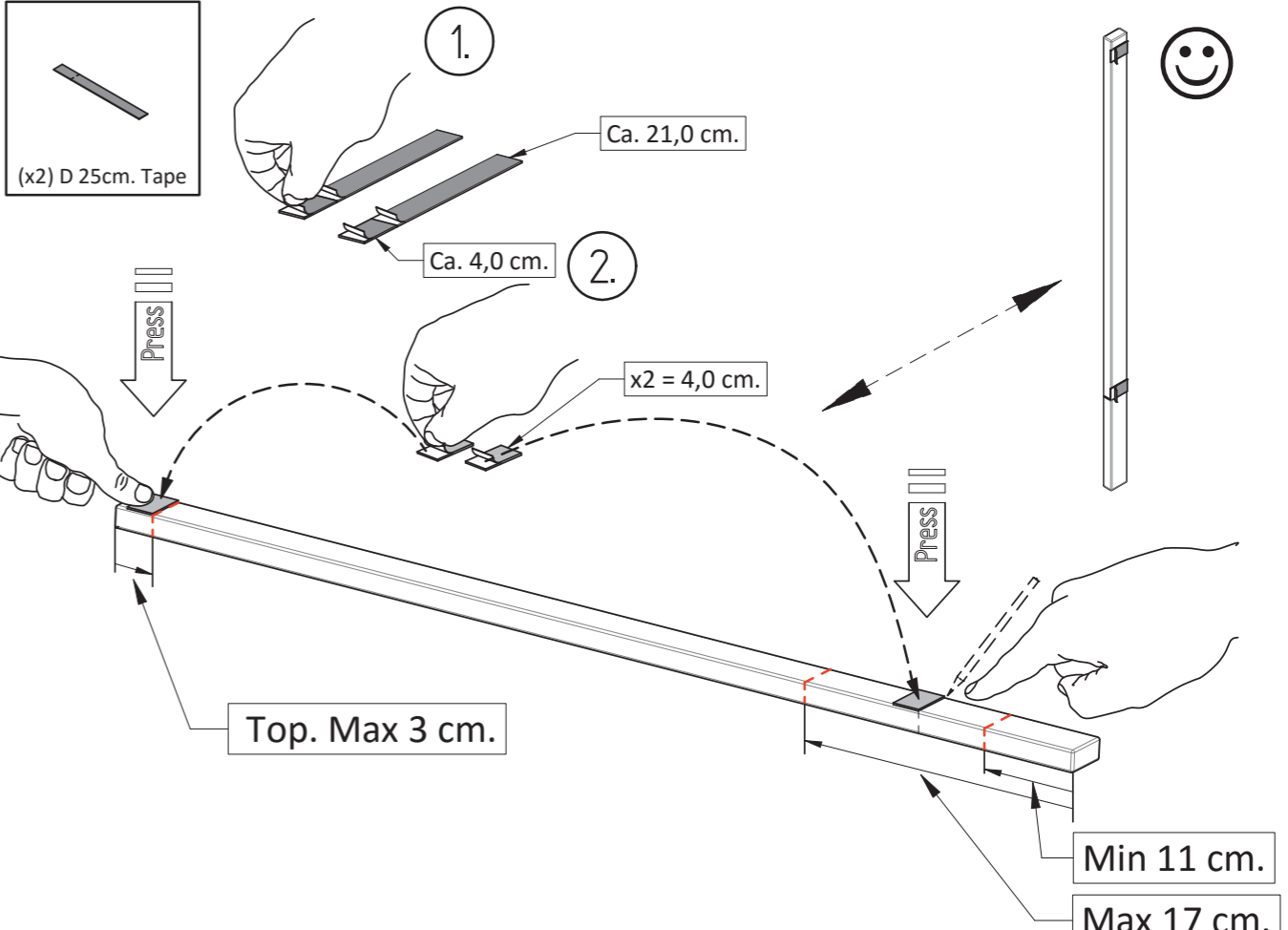

(x2) D 25cm. Tape. Ca. 21,0 cm. Ca. 4,0 cm. x2 = 4,0 cm. Top. Max 3 cm. Min 11 cm. Max 17 cm.

7

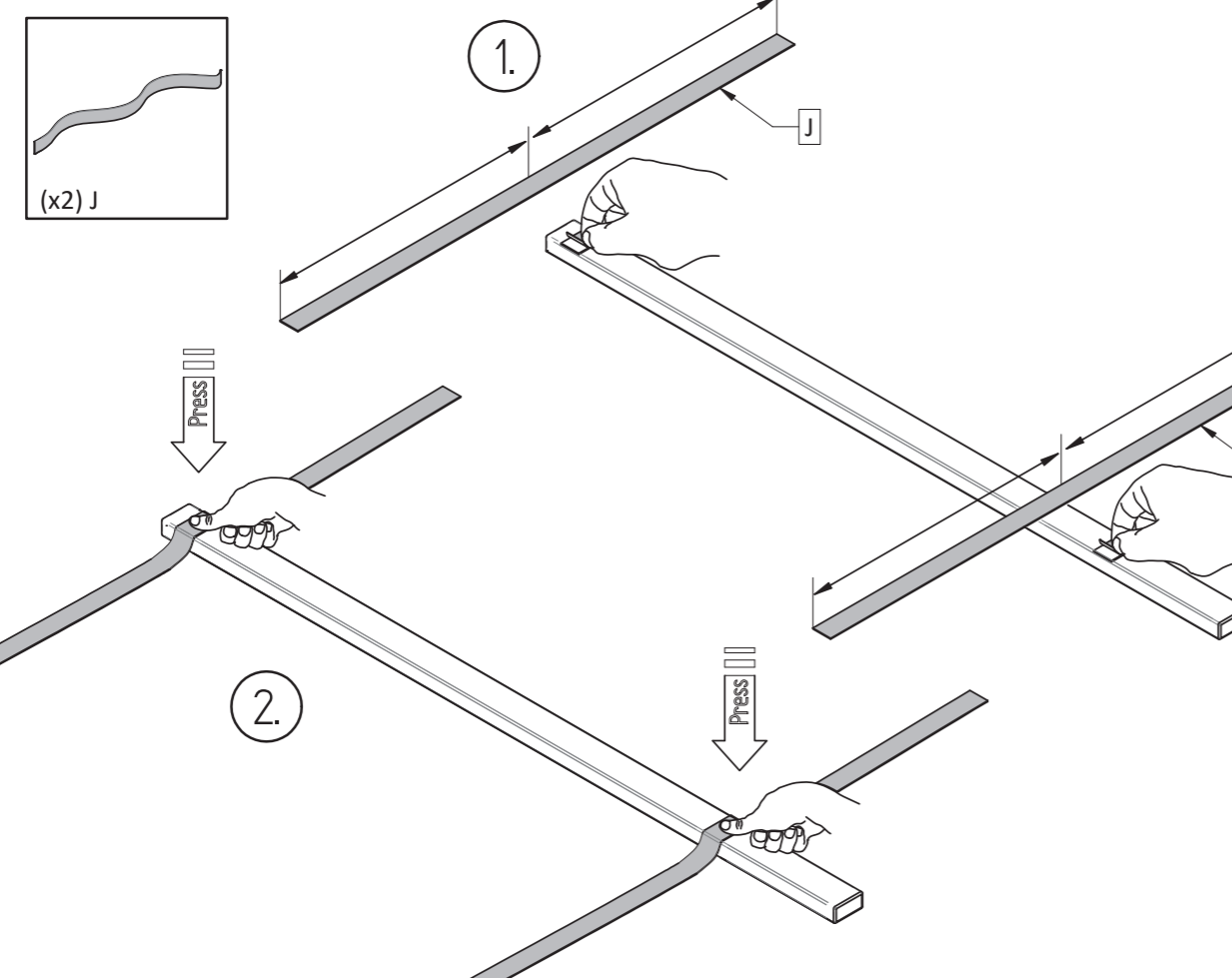

(x2) J.

8

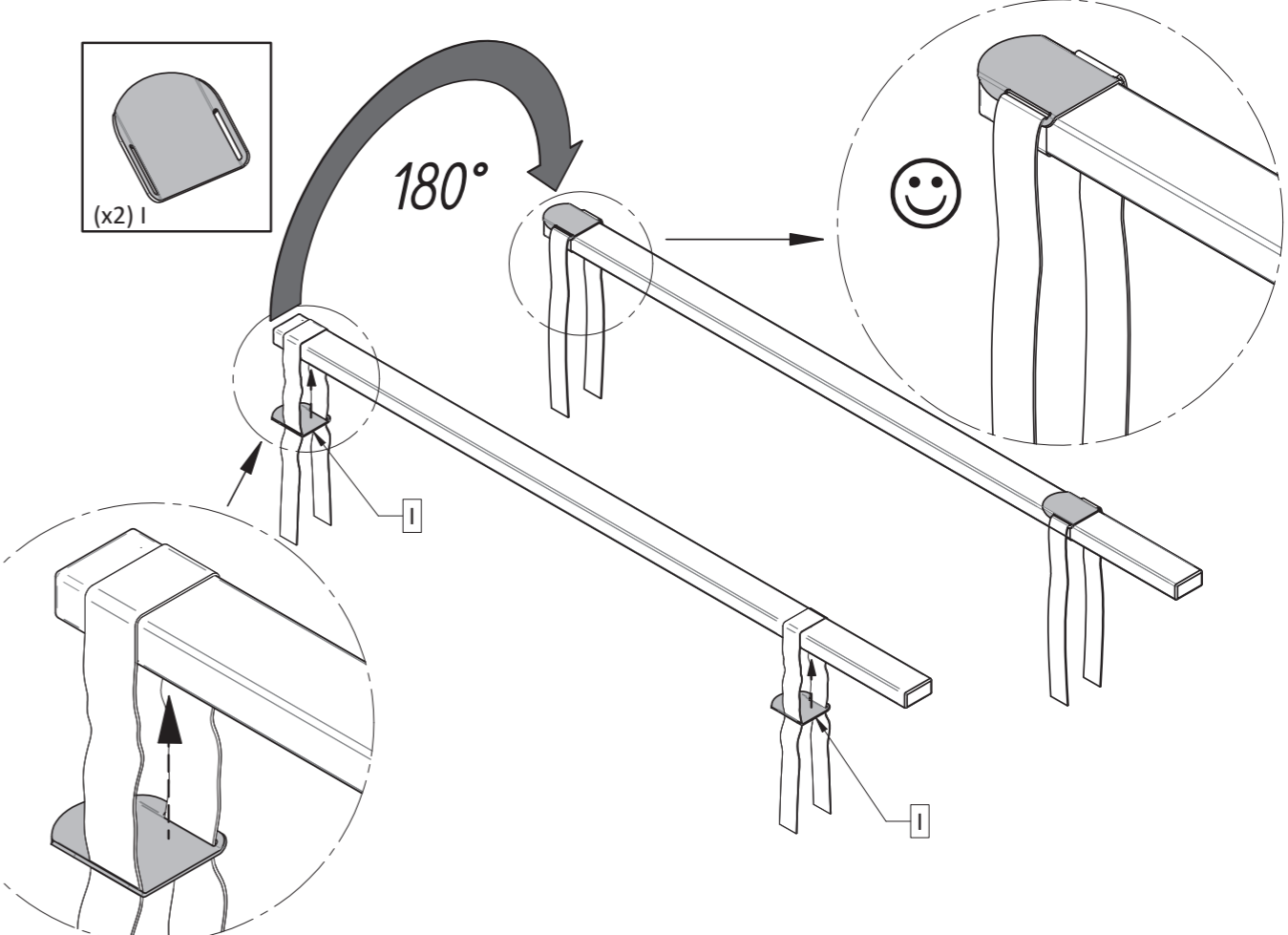

(x2) I. 180°.

9

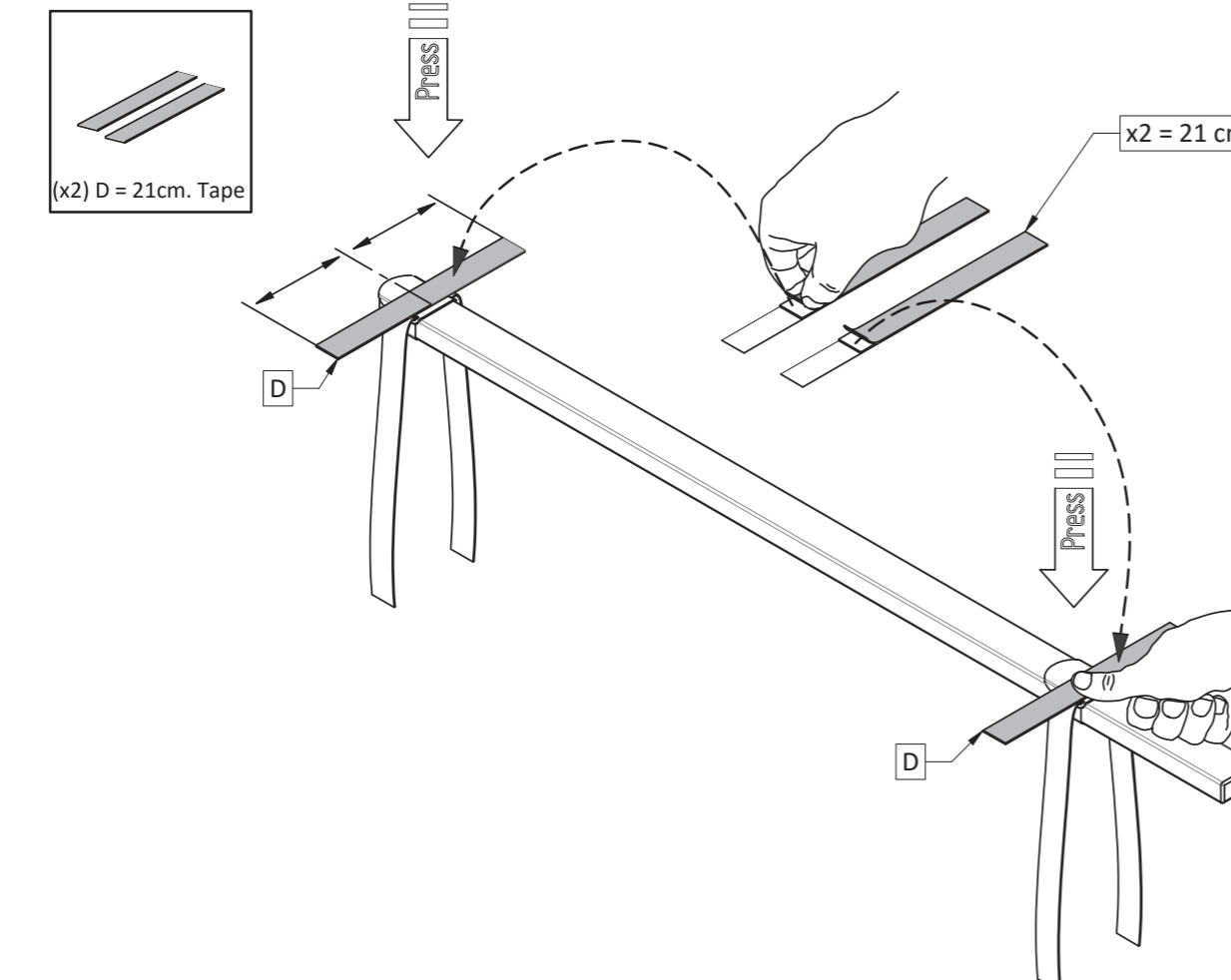

(x2) D = 21cm. Tape. x2 = 21 cm.

10

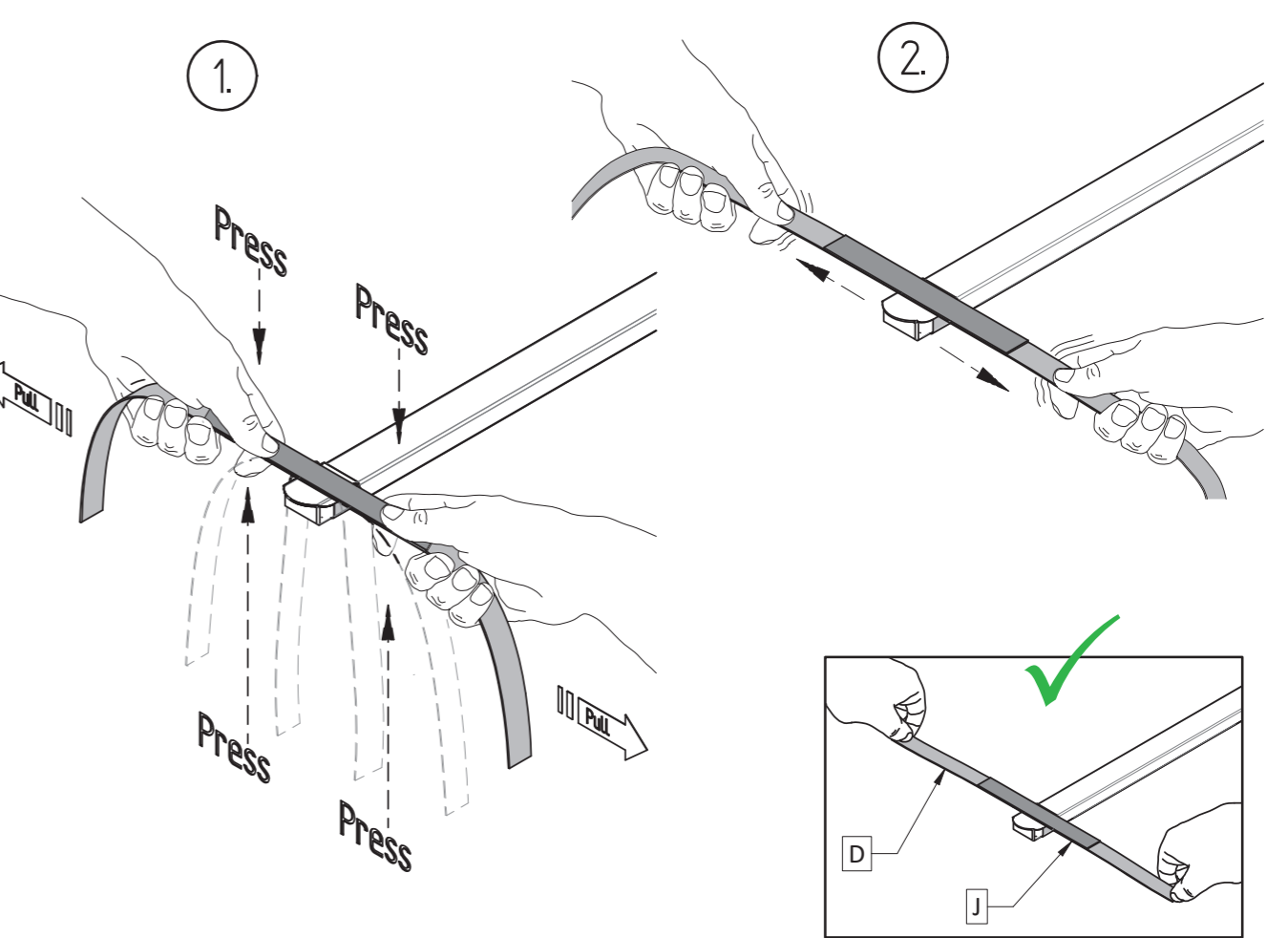

(x2) D = 21cm. Tape. x2 = 21 cm.

11

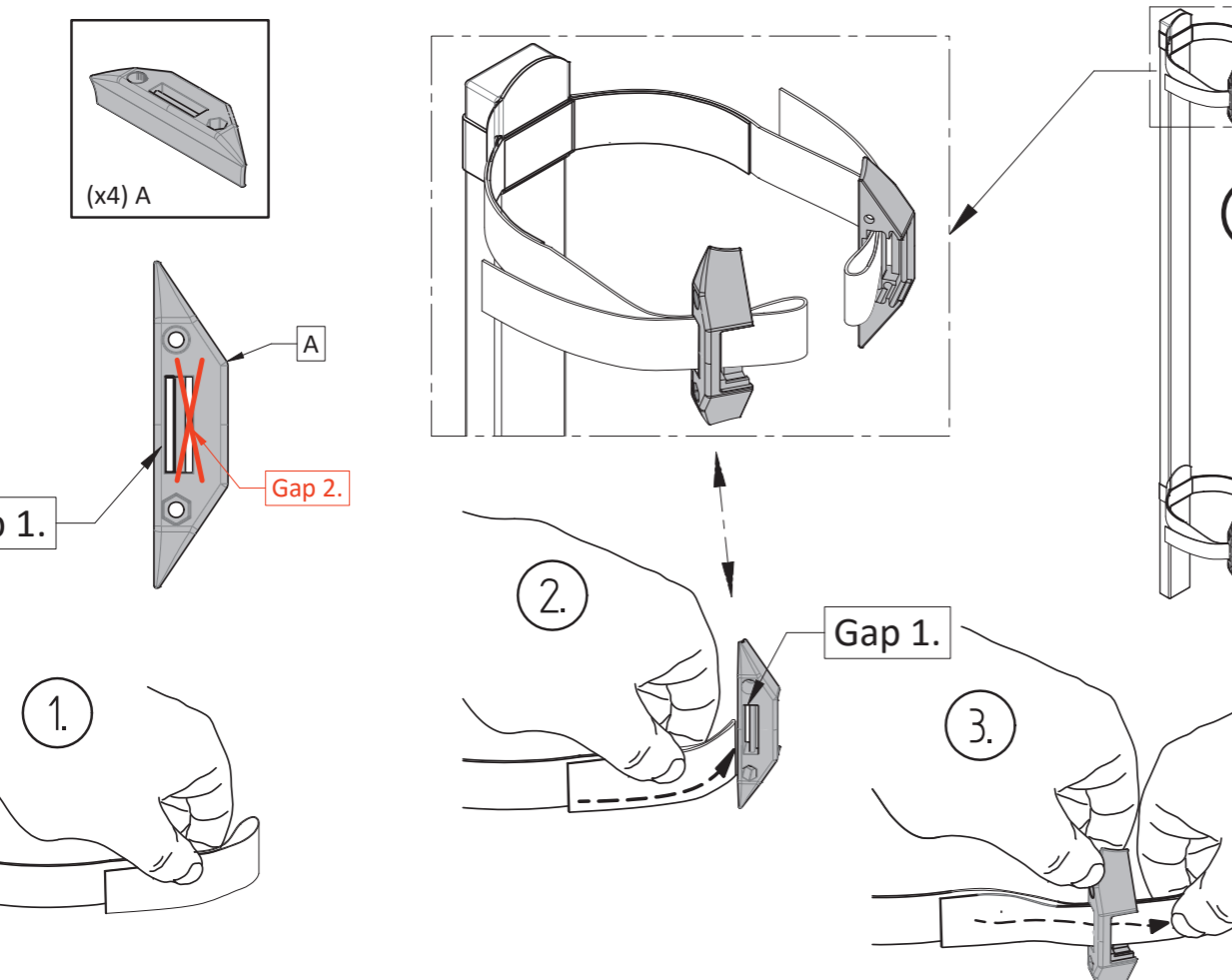

(x4) A. Gap 1. Gap 2.

12

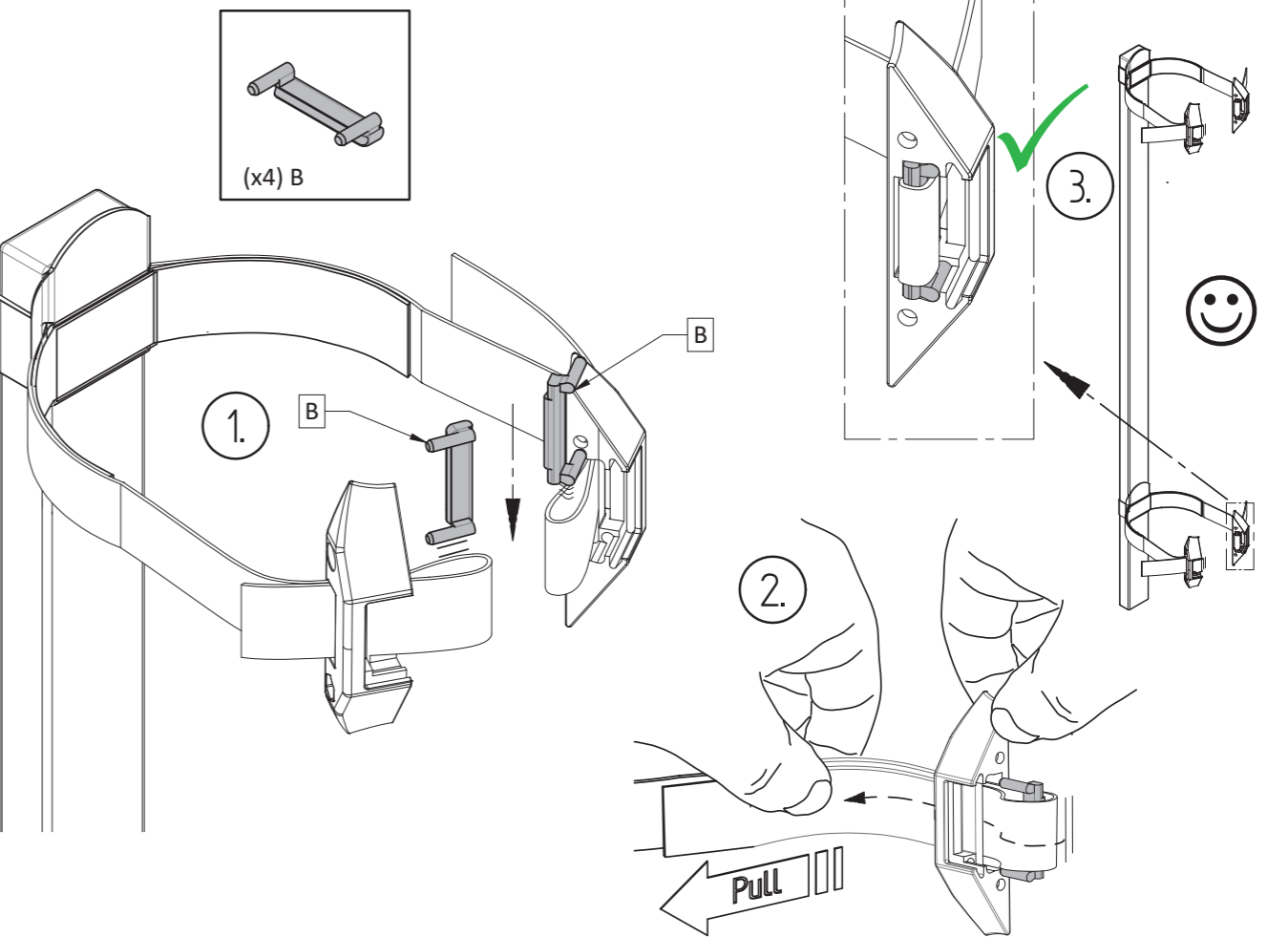

(x4) B. Pull.

